

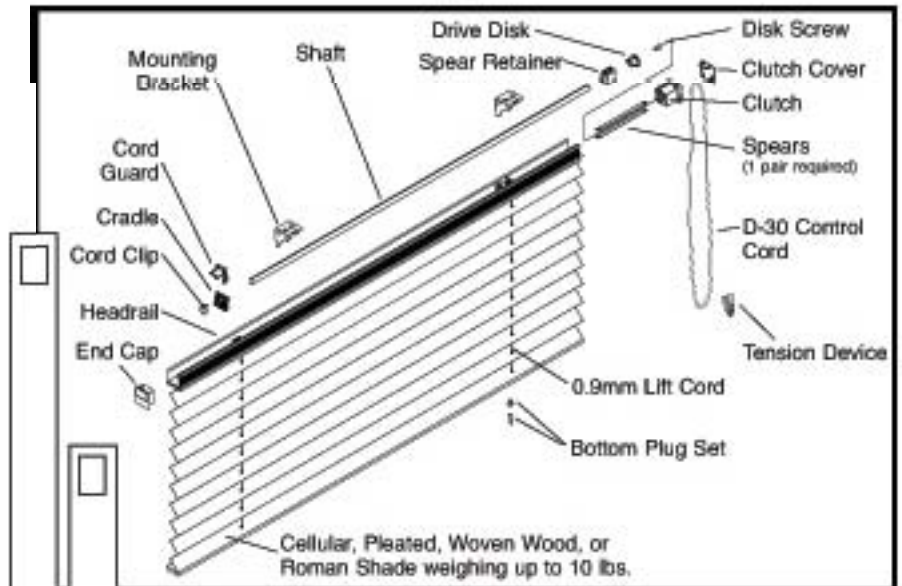

VersaRail® and RollEase® are trademarks of RollEase, Inc

Assembly



The diagrams in this instruction manual show 1 inch system components, the 1.5 inch system is assembled in exactly the same manner.

The maximum recommended drop length for use with this system is 12 ft. (3.6m) when using the recommended .9mm lift cord. Use of heavier cord would reduce this maximum.

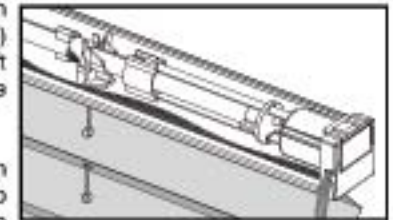

The shade is raised by its lift cords, which wrap around a shaft causing the shaft to traverse away from the clutch. The clutch drives the shaft via two spears and a drive disk. The shaft's traversing motion ensures that the lift cords wrap evenly on the shaft without overlapping on itself, keeping the shade absolutely level.

Spear length is the factor that limits the drop length of shades that can be built with this system as spear length corresponds to the amount the shaft can traverse. The amount the shaft can traverse determines how much lift cord can be wrapped onto the shaft.

Spears come in two lengths: a **long spear, part number: VSPR57** and **short spear, part number: VSPR46** and must be coordinated with the shades drop length. Shades between 9 ft. and 12 ft. in drop length (between 2.7m and 3.6m) **must** use the longer spear. Shades under 9 ft. in drop length (2.7m) may use either spear. Spears shown left are actual size.

PREPARING THE HEADRAIL AND FABRIC

1

- A. Cut the Headrail $\frac{3}{8}$ inch (9.52 mm) shorter than the width of the pleated fabric as allowance for the clutch housing. (Figure 1A)

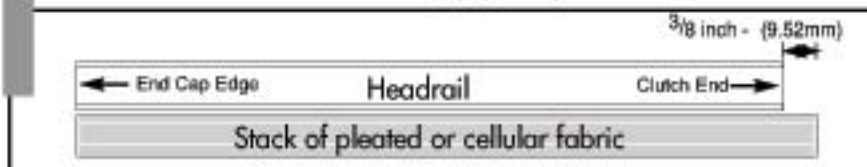

- B. Deburr both ends of the headrail for easy insertion of the clutch and end cap.
- C. Mark the headrail for punching or drilling the cradle holes. Locate the holes for cradles in accordance with spear length. A shade will operate well only if the spears do not touch the cradle. Spear length therefore determines the minimum distance between the edge at the fabric and the first route hole, as follows:
- When using the longer spears, the minimum distance is 7 inches (178mm).
 - When using the shorter spears, the minimum distance is 6 inches (152mm).

GEARBOX

OPTIONAL GEARBOX: see Page 13, Step 1

- When you mark locations for the cradle holes, one edge of the fabric must be flush with the "end cap edge" of the headrail, as shown above in Figure 1A.
- D. Punch or drill one hole per lift cord with a diameter of $\frac{3}{16}$ inch or between .186 inch (4.72 mm) and .191 inch (4.85 mm)
- E. Cut the lift cord 4 inches (100mm) longer than the shade drop.



OPTIONAL TOP DOWN: see Page 11, Step 1

- F. To prepare for the last assembly step 11, "Equalizing Lift Cord Tension" make slip knots at the bottom rail and leave an extra 1 inch (25mm) of lift cord below the knot.

INSERTING THE FABRIC INTO THE HEADRAIL

2

- A. Attach stiffener slat to the top fold(s) of the fabric before continuing.
- B. Drill the fabric (and slat) to align with the cradle holes.
- C. Slide the fabric all the way into the channel on the underside of the headrail, so the edge of the fabric lines up flush with the "end cap" edge of the headrail. The fabric should extend $\frac{3}{8}$ inch beyond the headrail at the other end, as shown above in Figure 1A.

PREPARING THE SHAFT/DRIVE DISK ASSEMBLY

3

- A. Cut a piece of shaft. For short spears (including gearbox) : cut the shaft 5 inches (127mm) shorter than the headrail. For long spears (including gearbox): cut the shaft 6 inches (152mm) shorter than the headrail. This provides room for the shaft to traverse.
- Both ends at the shaft must be burr-free and perfectly square.

- B. Attach the drive disk securely to one end of the shaft with the special screw (Figure 3B).
- Check that the drive disk is firmly attached to the shaft at right angles to the shaft.
 - Check that the screw is fully seated.

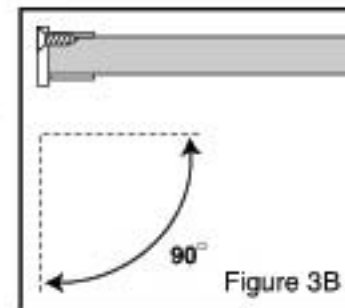

INSERTING THE CRADLES INTO THE HEADRAIL



OPTIONAL TOP DOWN: see Page 11, Step 2

4

- A. Insert the stem of each cradle into a hole in the headrail, with the cradle's shaft receiving area perpendicular to the walls of the headrail (Figure 4A).
- B. Twist the cradle 90° so the shaft receiving area faces towards the clutch end of the headrail and the cradle's wings slide under the inner lips of the headrail. (Figure 4B) shows installation for the clutch at the left end of the headrail.



After repeating for the other cradles check that all shaft receiving areas are facing towards the clutch end.

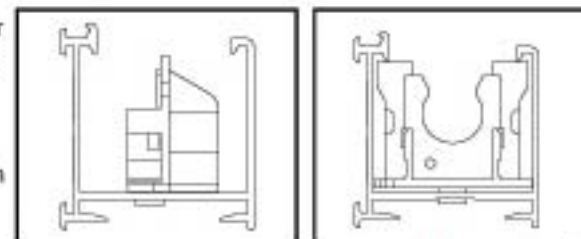

5

PREPARING THE LIFT CORDS AND SHAFT

- The system requires there to be some tension on all the lift cords at all times.
- A. Feed the "headrail end" of each lift cord up through the holes drilled in the shade (and optional slat) up through the hole in the cradle. Pull about 3 inches (75mm) of cord into the headrail.
- B. Tie a single overhand knot at the end of a cord. With the knot at the large opening of a cord clip, lay the cord into the clip's channel. Pull on the cord until the knot slips into the large opening (Figure 5B). Repeat for every cord.

- C. Lay all of the cord clips on the same side of the headrail - either all behind or all in front.



PREPARING THE CLUTCH

➤ The clutch can be prepared at any point before this.

- A. **IMPORTANT:** Do not disassemble the clutch.
- B. Select an appropriate cord length for the shade.
- C. Push a section of cord into the clutch as shown in figure 6C. Firmly push the cord clockwise against a tooth edge, until the pulley moves, trapping the cord in the pulley.
- D. Use a pencil eraser to rotate the pulley clockwise, one tooth at a time, all the way around to the other side. Figures 6D

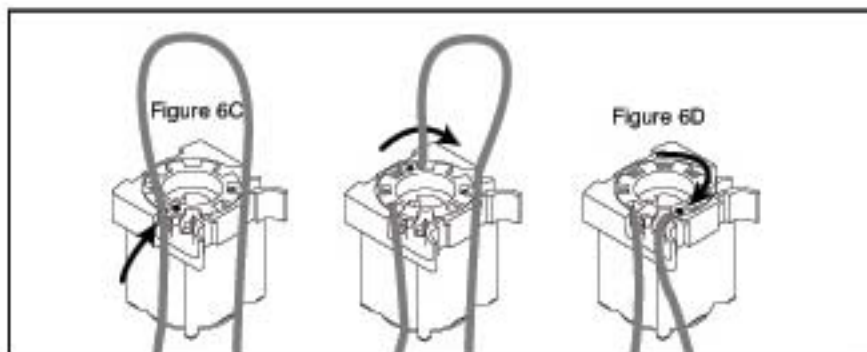

6

- E. Place the "L"-shaped feet of the clutch cover over the matching openings in the bottom of the clutch (Figure 6E).

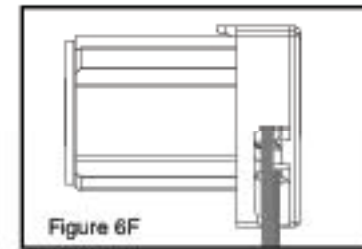
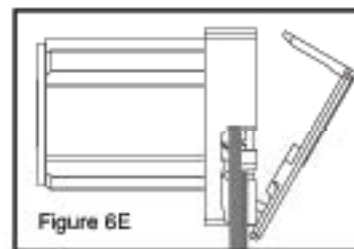

- F. While exerting upward pressure at the "hinge" formed in step 6E, carefully push the top of the cover into place at the top of the Clutch as shown (Figure 6F).

CONNECTING THE CLUTCH TO THE DISK SHAFT ASSEMBLY WITH SPEARS.



OPTIONAL GEARBOX: see Page 13, Step s 2 & 3

7

- A. Insert symmetrical Spears with square holes into the clutch. (Figure 7A)
Note: Once the Spear has been inserted, it cannot be removed.

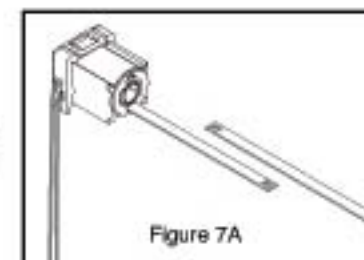

- B. Slide Spear Retainer (with its locking barbs facing away from the Drive Disk) and Drive Disk onto the Shaft. (Figure 7B)

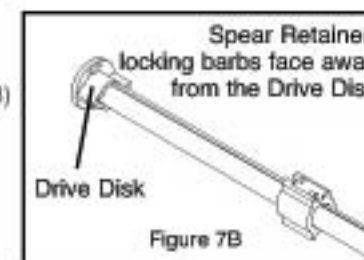

- C. Insert the spears already in the clutch through the drive disk onto the shaft. Slide the Spears into the Spear Retainer onto the locking barbs. (Figure 7C)

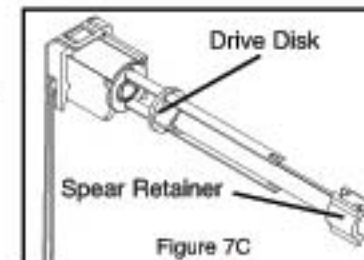

- D. Make sure that the locking bars in the Spear Retainer are in the holes of the Spears and Spears are securely snapped into the Clutch. (Figure 7D)
- E. Insert the shaft and clutch assembly into the headrail either from the clutch end of the headrail or from above.
 - > The upper lips of the headrail should fit into the grooves in the clutch housing.
 - > When inserting the shaft from above, be careful not to break the cradle or bend the shaft. Push down slowly and firmly on the shaft only at points that are directly above a cradle
- F. Check that the spears do not touch the Cradle.
- G. Insert the end cap into the other end of the headrail.
 - > Note that the fabric is now flush with the outer face of the clutch.

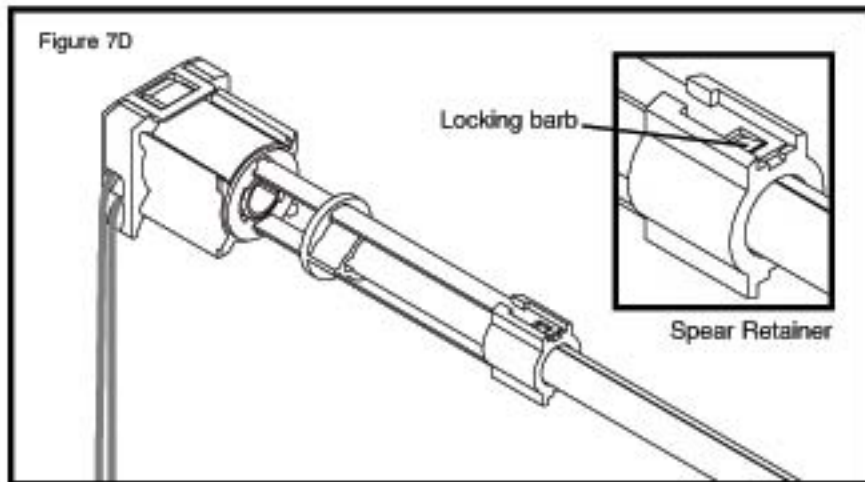

PREPARING THE SHAFT FOR LIFT CORD ATTACHMENT

8

- A. Slowly pull the control cord until one of the lines on the shaft is accessible.
- B. Slide the Shaft until the drive disk touches the clutch.
 - > The shaft must stay against the clutch until all cord clips have been attached to the shaft.

ATTACHING THE LIFT CORDS TO THE SHAFT



OPTIONAL TOP DOWN: see Page 12, Step 3

9

- A. Note (Figure 9A) that all of the cord clips must be attached to the shaft on the side of the cradle that faces away from the clutch. (shown below without cord guards for ease of viewing)



- B. Snap the cord guard to the cradle. (Figure 9B). The two arms of the cord guard will slide in between the double receiver arms of the cradle as shown. Once the cord guard is locked in place it is difficult to remove. When properly installed the cord guard will point away from the clutch side of the shade. (shown without shaft for ease of viewing in Figure 9B)
- C. With the knot facing away from the drive disk, and the cord clip as close as possible to the cord guard, fit the narrow rib that runs along the Clip's channel into the line along the top of the shaft (Figure 9C).
- D. Using the rib as a pivoting point apply pressure to the top of the clip with your thumb and push the cord clip until it snaps onto the shaft (Figure 9D).
- E. Pull on the knot to check that the cord is in the Clip's Channel and is not pinched between the clip and the shaft. (if the cord does not slide easily, redo this step without pinching the cord.)

