

- Check that all the clips are engaged on the same line of the shaft. Once the clutch is inserted this line must point straight down so all that all lift cords hang even.
- Check that all the clips are on the correct side of the headrail (I.e., away from the clutch).
- Cord clips should be positioned 1/8 to 1/4 inch away from the cord guard. Check that all cord clips are the same distance away from each cord guard. If one is 1/4 inch away, then they all should be 1/4 inch away. **Consistency of this distance is important.**
- Check that all the knots face away from the clutch end of the headrail.

HANGING THE SHADE

- Hang the shade perfectly level but do not release the shade fabric.
- The cords should be secured at the bottom with slip knots or the optional RollEase adjustable Bottom plugs. Taking care that the cords do not pop out at the fabric, slowly release the shade until it hangs to exactly its full desired length - no more, no less.
- If the pleated fabric is very springy, you may wish to attach weights to the fabric (to simulate the weight of the bottom rail). in order to get the shade to hang to its full length.
 - Check that the drive disk is fully against the clutch.
 - Make sure that the cords are not wrapped around the shaft at all and go straight from the cradle hole to the cord clip.
 - Check that the line into which the cord clips were aligned faces straight down. If necessary, rotate the shaft slightly (by operating the clutch) until the alignment line faces down.

10

11

EQUALIZING LIFT CORD TENSION AND ATTACHING THE BOTTOM RAIL

- Slide the bottom rail over the fabric either before or after adjusting the tension, according to the type of bottom rail you use.

- Adjust the tension at the bottom of the shade until all the lines have equal tension.
- Minor adjustments to the tension can be made by sliding the cord clips very slightly toward or away from the clutch.
 - Note: minor adjustments to cord tension using this method should be limited to no more than 1/8 inch.
 - Make sure that there is no slack, and that the tension in all the lift lines is equal.

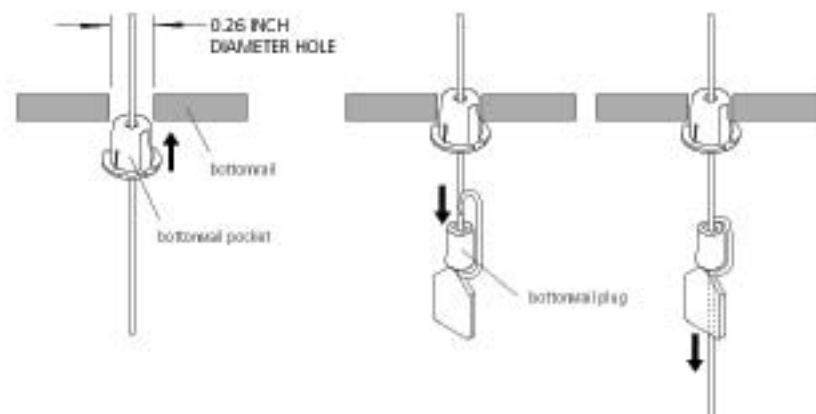

- Insert the lift cord through the bottom rail pocket and push the pocket into the bottom rail.
- Thread the lift cord through the bottom rail plug as shown, leaving a few inches of extra lift cord below the plug.

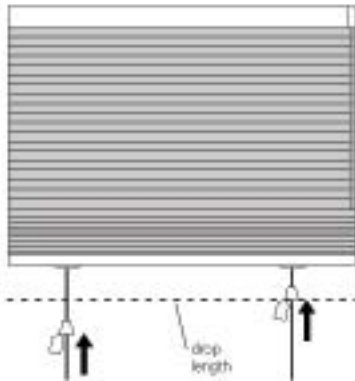

- E. Lift shade fabric and bottomrail up while measuring drop length of lift cords. Slide the plugs up or down the lift cord so that the bottom of the plug is at the drop length.

Note: Drop length must allow at least 1/8 inch clearance above the window sill.

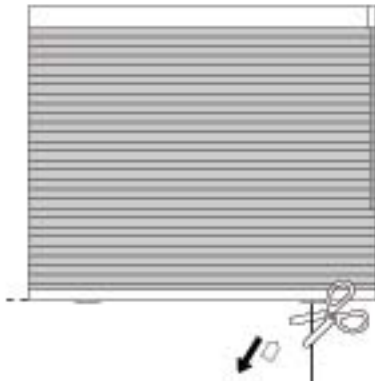

- F. Lower shade fabric and bottom rail up and push the plugs into the bottomrail pockets. Cut excess cord and remove tabs from plugs.

TESTING THE SHADES OPERATION

- A. When the shade is all the way down, check that pulling on the control cord in either direction raises the shade.
- B. Raise the shade all the way and check that the lift cords are wrapped neatly in a single layer around the shaft.
- C. Lower the shade all the way and check that the drive disk has returned within 1/2 inch (13mm) of the clutch. (This test requires looking into the headrail from above.)

The drive disk must return to the clutch by itself. If it does not, gradually add weight to the bottom rail until the shade is heavy enough to bring the disk all the way back to the clutch. Add the weight uniformly across the bottom rail.

If the shade fails any of these "tests" and a simple review of the instructions does not solve the problem please contact RollEase, Inc. at 1.800.552.5100, or 203.964.1573

Thank you.

12

TOP DOWN

OPTION



Preface:

A top-down only shade can be made from existing RollEase components. The top down only shade will require a top rail in addition to a bottom rail. The bottom rail may hang freely or be secured to the window sill. The top rail will be raised by wrapping lift line on the traversing shaft. The moving top rail and stack of cellular fabric will be guided by a static track-guide cord secured at the top by a knot through the track-guide hole in the cradle. Both the track-guide cord and the lift line will share the same route hole in the cradle and the hole in the top rail.

1. DOUBLE CORDS REQUIRED.

A top down only shade will use two cords per route hole. One to lift the shade, one to guide the top rail and fabric. The lift line should be assembled to the traversing shaft as usual but will be secured to the top rail rather than to a bottom rail as with a bottom-up shade. Track Guide Cord will be secured with a knot through a hole drilled in the cradle and will run down through the top rail, through the fabric and be secured into the bottom rail. Both lift cord and track guide cord should be assembled so that they are always taut without any slack.

Return to Page 2 and continue with Step 1F.

2. PREPARING THE CRADLES

Use the correct components. The top-down option cradle has track-guide cord knot-hole. (see figure 2)

If your cradle does not have the hole molded into it, one needs to be drilled. Use a 1/16th drill bit in the location as shown.

Note: All cradles now sold have this hole molded into them.

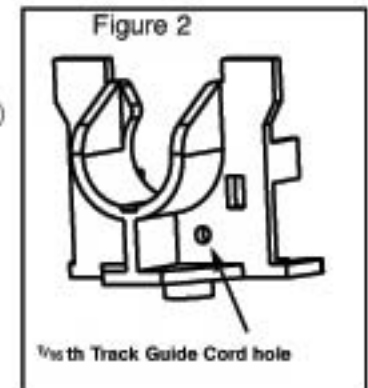

Return to Page 3 and continue with Step 4.



TOP DOWN

OPTION

3. ATTACHING TRACK-GUIDE CORDS, LIFTS CORDS

The track-guide cords should be slipped through the route hole in the cradle along with lift cord. The track guide cord will feed through the track guide hole in the cradle.

(See Figure 3A)

Tie a knot in the track guide cord and gently pull it snug against the cradle. (see Figure 3B) Cut off any excess tail after the knot so that it doesn't interfere with the shaft. The lift cord attaches to the shaft as usual. Feed the track guide cord down through the top rail and the fabric to the bottom rail where it should be secured. The track guide cord should always be taut with no slack.

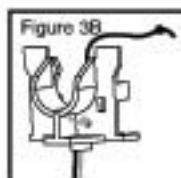
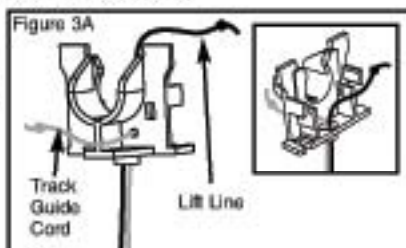

Note: Do not twist Track Guide Cords with Lift Cords.

For top down only shades the bottom of the lift cords will attach to the top rail.

Return to Page 7 and continue with Step 9A.

4. EQUALIZING TENSION

Top down only shades require that both the track-guide cords and the lift cords always have tension on them with out any

slack. First adjust the tension on the track-guide cords and then on the lift cords.

Return to Page 9 and continue with Step 11A.

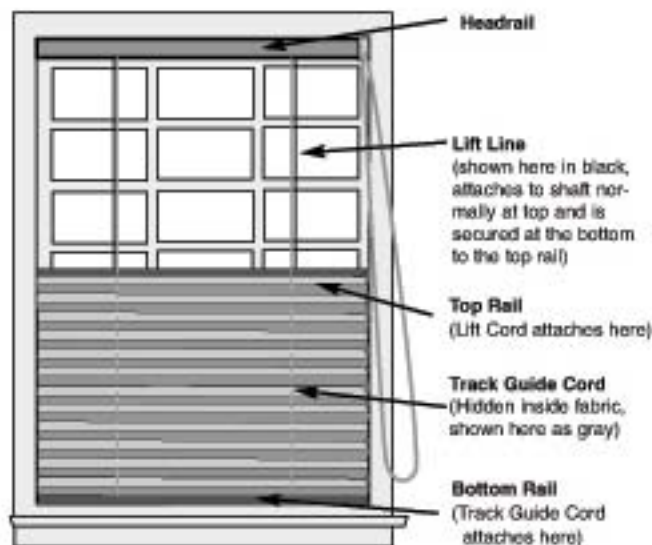

GEARBOX

OPTION

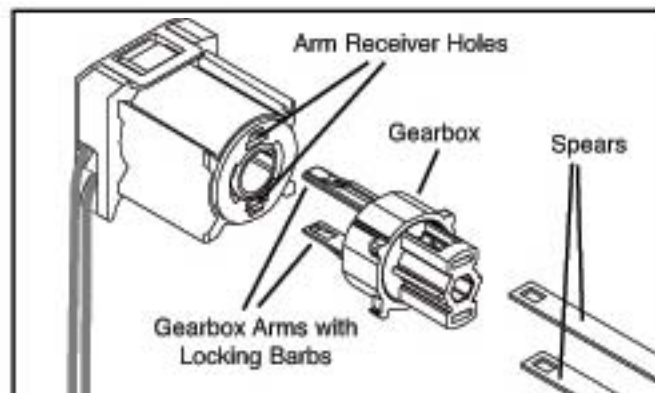

1. > When using the longer spears with gearbox the minimum edge distance is 8.5 inches (216 mm)
- > When using the shorter spears with gearbox the minimum edge distance is 7.5 inches (191 mm)

Return to Page 2 and continue with Step 1D.

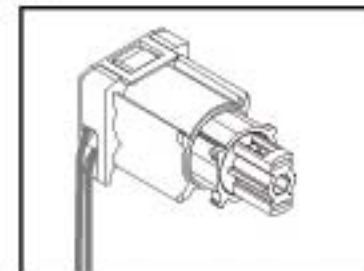
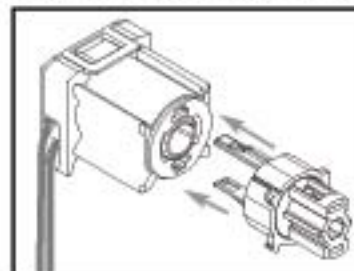

2. Insert the two arms of the gearbox into the arm receiver holes on the clutch. Push in until the locking barbs on the arm engage and lock into the clutch.

Note: Once the Arms have been inserted, they cannot be removed.

3. Insert the spears into the spear ports in the gearbox until securely locked in position.

Return to Page 5 and continue with Step 7B.

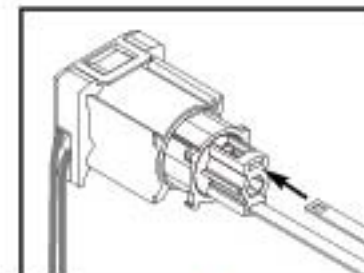

WOVEN WOOD/SOFT SHADE OPTION

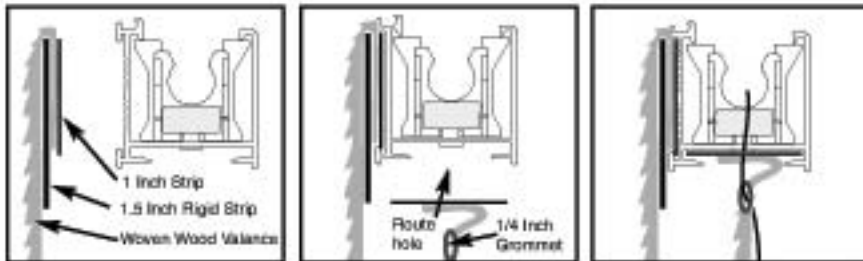

Prepare the Valance

1. Staple the woven wood valance and its 1.5 inch rigid strip to a 1 inch strip as wide as your shade. Make sure that when stapled together the highest portion of the woven wood shade will be flush with the top of the headrail. (especially important of top mounted shades).
2. Slide the inch strip into the front channel of the headrail.

Prepare the Woven Wood Shade

3. Take a section of 1 inch strip as wide as your shade. Measure, mark and drill a 1/8 inch hole centered in the locations of your lift lines.
4. Staple the top of the woven wood shade to the 1 inch strip. Drill a 1/16th inch hole through the woven wood shade through the center of the hole in the 1 inch strip.
5. Measure down 3-4 inches from each hole, mark and crimp in a 1/4 inch (or smaller) grommet.
6. Slide the inch strip, with woven wood shade attached, into the bottom channel of the headrail, making sure the lift line holes align with the cradle exits ports.
7. Feed your lift down through the cradle and through the grommet so that the lift line feeds behind the shade.

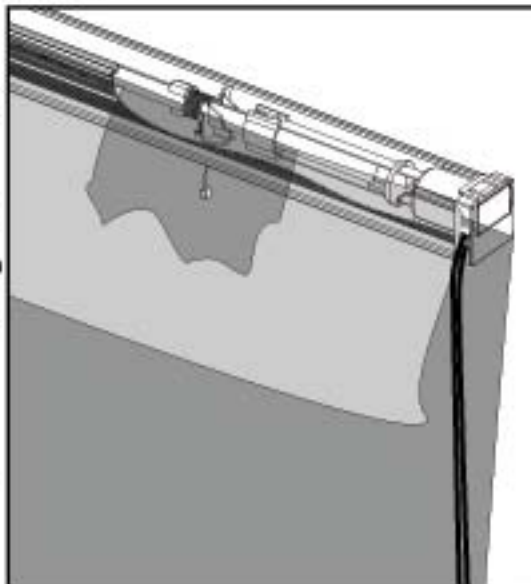

Trouble shooting

Transporting Instructions:

- Always transport the shade in the all-the-way-up position.

Some Tips for Your Customers:

- Do not force shade past its comfortable high/low positions.
- Do not put objects on the sill where the shade might rest on them.
- Do not operate the shade while lifting a corner to peer out the window.

The Shade Rises Unevenly, Does Not Return, or is Noisy?

Note: If a shade should ever hang unevenly, lower it all the way down and then raise it again.

- 1) Lift cords are not uniformly taut (check when the blind is fully lowered, all lift lines should have equal tension on them). Lift cords should never be slack in any position.
- 2) Cord clips need to be uniformly spaced on the shaft from the cradle (ie; don't have one clip 1/2 inch away from the cord guard or cradle and another 2 inches away.) Use the cord guard as a reference, cord clips may start as close to the cord guard as possible.
- 3) Tails of knots in the cord clips must be facing away from the clutch. Tie a single knot only, multiple knots will prevent the knot head from being pulled inside the knot head cavity in the cord clip.
- 4) When in the fully lowered position there shouldn't be any cord wrapped on the shaft at all.
- 5) Lift cords may wrap around cord clips because there's not enough room between lift lines. (need to allow 1 inch of shaft space for every 3 feet of drop)
- 6) Blind catching in window...check to make sure window hardware or crank is not an obstruction.
- 7) Shaft Bent or warped?
- 8) Drive disk not square on the shaft. Was the shaft cut square? Was the shaft deburred when cut?
- 9) Mounting bracket is not close enough to the clutch? When control cord is pulled, headrail may be temporarily twisted enough to put shaft out of alignment with cradles. Brackets mounted close to clutch help prevent any headrail twisting.

Control Cord Slipping in Clutch?

- 1) Are you using D-30 control cord? D-30 is the only approved control cord, anything else is likely to slip in clutch.
- 2) Shade too heavy? 10 lbs maximum.

RollEase, Inc. 200 Harvard Ave Stamford, CT 06902-6320
800.552.5100 203.964.1573 Order Fax: 203.358.5865 www.rollease.com